

Model: TSB13302C-3B*

| No. | Item | Symbol | Unit | Specification | No. | Item | Symbol | Unit | Specification |
|-----|----------------------|--------|-------|------------------|-----|----------------------|--------|--------------------|----------------|
| 1 | Drive | - | - | Retangular Wave | 13 | Roter Inertia | J-M | kg-cm ² | 12.54 ±10% |
| 2 | Cooling Method | - | - | Totally Enclosed | 14 | Rated Power Rate | Q-R | Kw/s | 72.65 |
| 3 | Exciting Method | - | - | Permanent Magnet | 15 | Resistance | Ra | Ω | 0.247 ±10%/2 φ |
| 4 | Resolution | - | - | NOTTE2. | 16 | Inductance | L | mH | 1.62 ±10%/2 φ |
| 5 | Rated Output | P-R | W | 3KW | 17 | Mech. Time Constant | Tm | ms | 0.81 ±10% |
| 6 | Rated Torque | T-R | N-m | 9.545 | 18 | Elect. Time Constant | Te | ms | 6.57 ±10% |
| 7 | Max. Torque | T-max | N-m | 28.645 | 19 | Insulation Class | - | - | Class B |
| 8 | Rated Speed | N-R | rpm | 3000 | 20 | Operation Temp. | T | °C | 0~40 |
| 9 | Rated Current | I-R | A | 14 | 21 | Operation Humid. | RH | % | <90 |
| 10 | Max. Current | I-max | A | 42 | 22 | Storage Temp. | T | °C | -20~60° |
| 11 | Torque Constant | Kt | N-m/A | 0.73 ±10% | 23 | Storage Humid. | RH | % | <90 |
| 12 | Back emf(at 1800rpm) | Vemf | Volts | 81.38 ±10%/2 φ | 24 | Weight | W | kgw | 13.04 |

Notes:
 1. Motor to be IP67
 (excluding the shaft opening & connectors)
 2. Encoder TYPE: 2500ppr, 8192ppr
 17bit , 15bit

AC SERVO MOTOR
 Model : TSB13302C-3B*
 Pr : 3 kw Nr : 3000 rpm
 Ir : 14A Tr : 97.4 kg-cm
 NO : 0000000000
 TSCB ELECTRIC COMPONENTS
 100, LITZ MADE IN TAIWAN

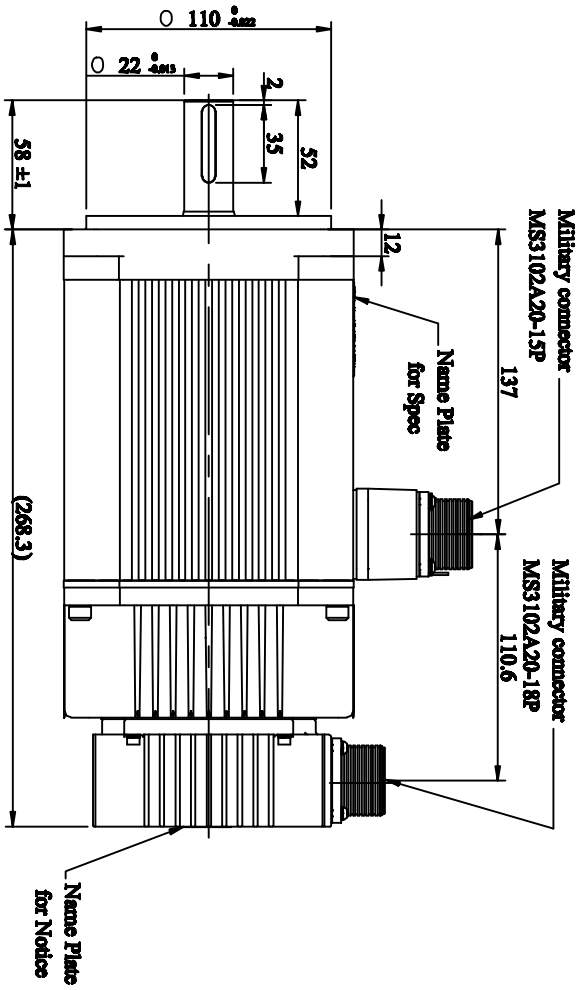
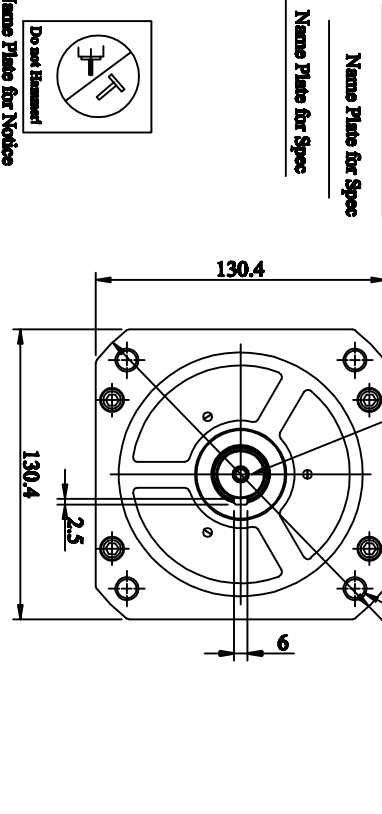

Do not Etchant
 Name Plate for Notice

| STANDARD TOLERANCE | | APVD | CHKD | CHKD | DWN | S.J.Lhm | 05-12-10 | SCALE | 1/3 | UNIT | m m | NAME | Servo Motor Outline Drawing |
|--------------------|-------|------|------|------|-----|---------|----------|---------|-----|------|-----|------|-----------------------------|
| X | ±0.5 | | | | | | | 3RD A/P | | | | | TSB13302C-3B* |
| XX | ±0.2 | | | | | | | | | | | | |
| XX | ±0.05 | | | | | | | | | | | | |
| ANGLE | ±30' | | | | | | | | | | | | |
| MATERIAL | | | | | | | | | | | | | |

| REV | DESCRIPTION | SIGNATURE | DATE |
|-----|-------------|-----------|------|
| | | | |

| REV | DESCRIPTION | SIGNATURE | DATE |
|-----|-------------|-----------|------|
| | | | |

| REV | DESCRIPTION | SIGNATURE | DATE |
|-----|-------------|-----------|------|
| | | | |